

# 分相始動式モータ

## 開放防滴型 (EFOU-KT)

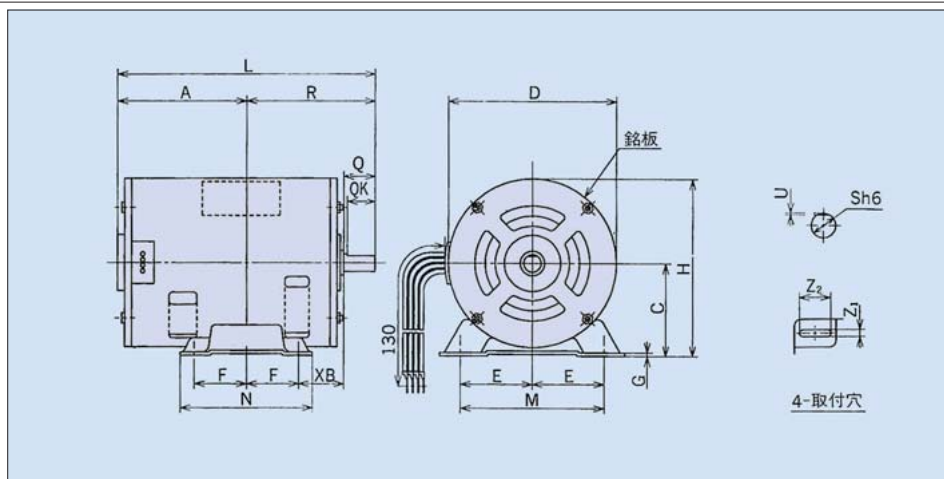

## 全閉外扇型 (TFO-KT)

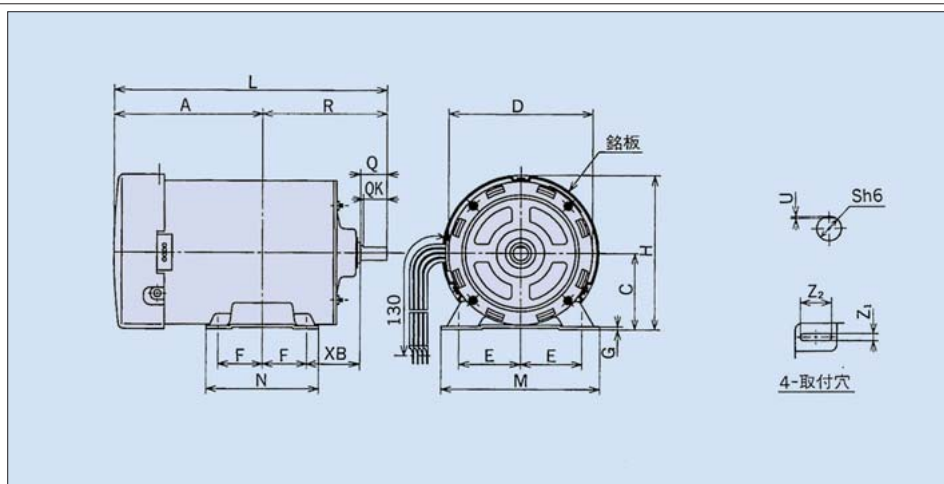

## 防振型 (EFNOU-KT)

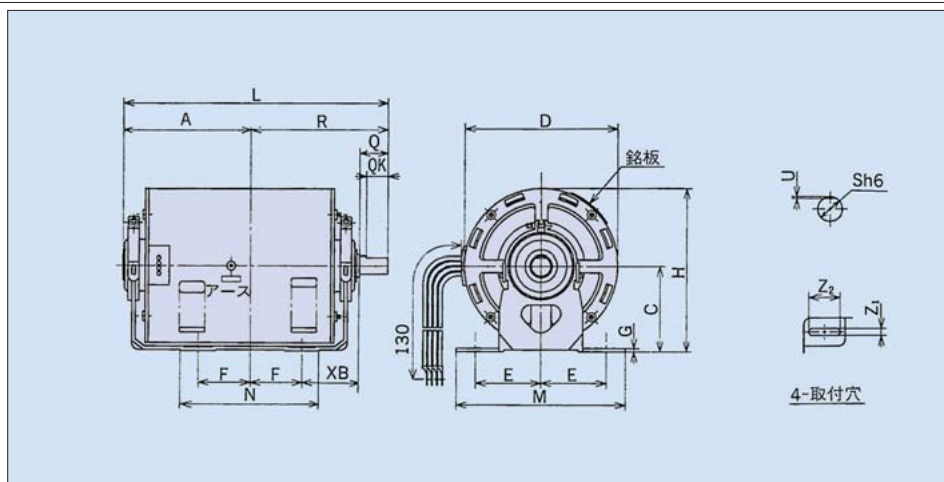

### ■寸法表

型 式	出力 (W)	モ ー タ (mm)													軸 端				軸受番号		質量 (kg)		
		L	R	A	D	H	C	F	E	N	M	G	Z <sub>1</sub>	Z <sub>2</sub>	XB	S	U	Q	QK	負荷側	反負荷側	単体	荷造
EFOU-KT	100	196	120	76	131	137	71 <sup>+0.5</sup> <sub>0</sub>	45	56	110	150	3.2	7	26	45	14	1	30	27	6202ZZ	6202ZZ	5.0	5.5
◇	200	211	120	91	131	137	71 <sup>+0.5</sup> <sub>0</sub>	45	56	110	150	3.2	7	26	45	14	1	30	27	6202ZZ	6202ZZ	6.4	6.9
◇	250	226	120	106	131	137	71 <sup>+0.5</sup> <sub>0</sub>	45	56	110	150	3.2	7	26	45	14	1	30	27	6202ZZ	6202ZZ	7.8	8.3
TFO-KT	200	242	120	122	147	145	71 <sup>+0.5</sup> <sub>0</sub>	45	56	110	150	3.2	7	26	45	14	1	30	27	6202ZZ	6202ZZ	7.3	7.8
EFNOU-KT	100	208	120	88	131	137	71 <sup>+1</sup> <sub>-0.5</sub>	45	56	110	150	2.3	8	26	45	14	1	30	27	6202ZZ	6202ZZ	5.2	5.7
◇	200	218	120	98	131	137	71 <sup>+1</sup> <sub>-0.5</sub>	45	56	110	150	2.3	8	26	45	14	1	30	27	6202ZZ	6202ZZ	6.5	7.0
◇	250	238	120	118	131	137	71 <sup>+1</sup> <sub>-0.5</sub>	45	56	110	150	3.2	8	26	45	14	1	30	27	6202ZZ	6202ZZ	7.9	8.4

(注) 寸法は変更になることもありますので、設計用には寸法図をご請求ください。